

Scheme of Learning

Year 6

#MathsEveryoneCan



**White**

**Rose  
Maths**

Spring - Block 5

**Perimeter, Area & Volume**

# Overview

## Small Steps

## NC Objectives

- ▶ Shapes – same area
- ▶ Area and perimeter
- ▶ Area of a triangle (1)
- ▶ Area of a triangle (2)
- ▶ Area of a triangle (3)
- ▶ Area of parallelogram
- ▶ Volume – counting cubes
- ▶ Volume of a cuboid

Recognise that shapes with the same areas can have different perimeters and vice versa.

Recognise when it is possible to use formulae for area and volume of shapes.

Calculate the area of parallelograms and triangles.

Calculate, estimate and compare volume of cubes and cuboids using standard units, including  $\text{cm}^3$ ,  $\text{m}^3$  and extending to other units ( $\text{mm}^3$ ,  $\text{km}^3$ )

# Shapes – Same Area

## Notes and Guidance

Children will find and draw rectilinear shapes that have the same area.

Children will use their knowledge of factors to draw rectangles with different areas. They will make connections between side lengths and factors.

## Mathematical Talk

What do we need to know in order to work out the area of a shape?

Why is it useful to know your times-tables when calculating area?

Can you have a square with an area of  $48 \text{ cm}^2$ ? Why?

How can factors help us draw rectangles with a specific area?

## Varied Fluency

Sort the shapes into the Carroll diagram.

	Quadrilateral	Not a quadrilateral
Area of $12 \text{ cm}^2$		
Area of $16 \text{ cm}^2$		

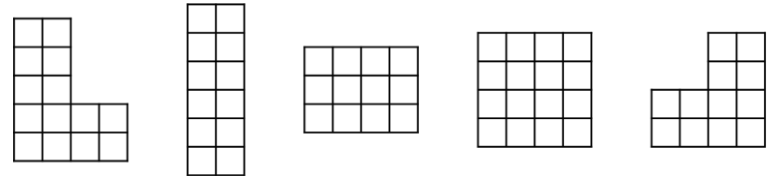

Now draw another shape in each section of the diagram.

How many rectangles can you draw with an area of  $24 \text{ cm}^2$  where the side lengths are integers?

What do you notice about the side lengths?

Using integer side lengths, draw as many rectangles as possible that give the following areas:

$17 \text{ cm}^2$

$25 \text{ cm}^2$

$32 \text{ cm}^2$

# Shapes – Same Area

## Reasoning and Problem Solving

Rosie and Dexter are drawing shapes with an area of  $30\text{cm}^2$



Dexter's shape

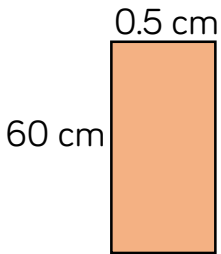

Rosie's shape

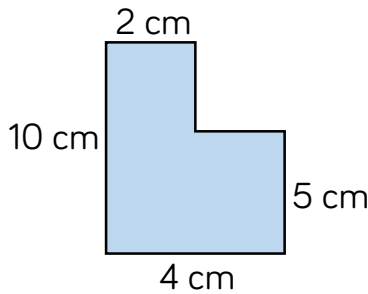

Both are correct.

Dexter's shape:  
 $60\text{ cm} \times 0.5\text{ cm} = 30\text{ cm}^2$

Rosie's shape:  
 $2\text{ cm} \times 10\text{ cm} = 20\text{ cm}^2$   
 $5\text{ cm} \times 2\text{ cm} = 10\text{ cm}^2$   
 $20\text{ cm}^2 + 10\text{ cm}^2 = 30\text{ cm}^2$   
 Could be split differently.

Who is correct?

Explain your reasoning.

Three children are given the same rectilinear shape to draw.

Amir says, "The smallest length is 2 cm."  
 Alex says, "The area is less than  $30\text{ cm}^2$ ."  
 Annie says, "The perimeter is 22 cm."

What could the shape be?  
 How many possibilities can you find?

### Always, Sometimes, Never?

If the area of a rectangle is odd then all of the lengths are odd.

Children can use squared paper to explore. Possible answers:

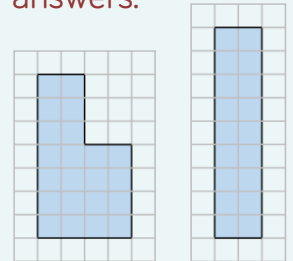

Sometimes –  
 $15\text{ cm}^2$  could be  
 $5\text{ cm}$  and  $3\text{ cm}$  or  
 $60\text{ cm}$  and  
 $0.25\text{ cm}$

# Area and Perimeter

## Notes and Guidance

Children should calculate area and perimeter of rectilinear shapes. They must have the conceptual understanding of the formula for area by linking this to counting squares. Writing and using the formulae for area and perimeter is a good opportunity to link back to the algebra block.

Children explore that shapes with the same area can have the same or different perimeters.

## Mathematical Talk

What is the difference between the area and perimeter of a shape?

How do we work out the area and perimeter of shapes?  
Can you show this as a formula?

Can you have 2 rectangles with an area of  $24 \text{ cm}^2$  but different perimeters?

## Varied Fluency

Look at the shapes below.

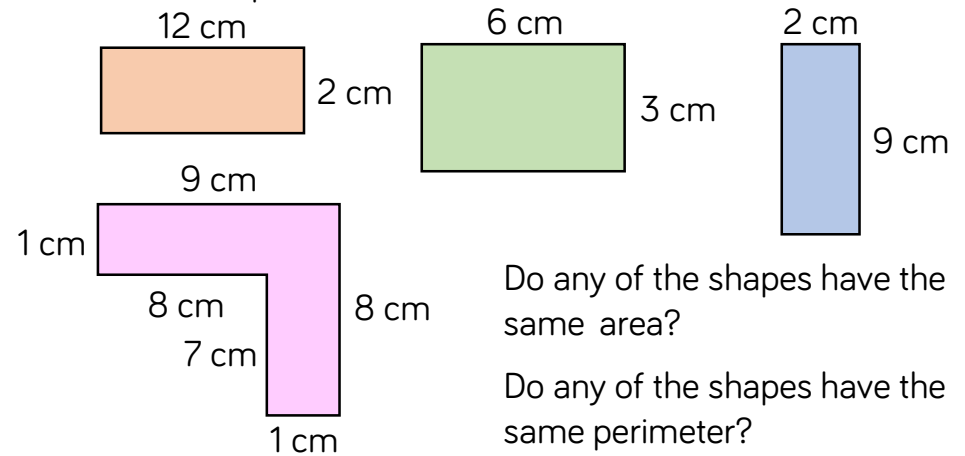

Work out the missing values.



Draw two rectilinear shapes that have an area of  $36 \text{ cm}^2$  but have different perimeters.

What is the perimeter of each shape?

# Area and Perimeter

## Reasoning and Problem Solving

### True or false?

Two rectangles with the same perimeter can have different areas.

Explain your answer.

A farmer has 60 metres of perimeter fencing.

For every 1 m<sup>2</sup> he can keep 1 chicken.



How can he arrange his fence so that the enclosed area gives him the greatest area?

True. Children explore this by drawing rectangles and comparing both area and perimeter.

The greatest area is a 15 m × 15 m square, giving 225 m<sup>2</sup>

Children may create rectangles by increasing one side by 1 unit and decreasing one side by 1 unit e.g.  
 $16 \times 14 = 224 \text{ m}^2$   
 $17 \times 13 = 221 \text{ m}^2$

Tommy has a 8 cm × 2 cm rectangle. He increases the length and width by 1 cm.

Length	Width	Area
8	2	
9	3	

He repeats with a 4 cm × 6 cm rectangle.

Length	Width	Area
4	6	

What do you notice happens to the areas?

Can you find any other examples that follow this pattern?

Are there any examples that do not follow the pattern?

If the sum of the length and width is 10, then the area will always increase by 11

Children may use arrays to explore this:

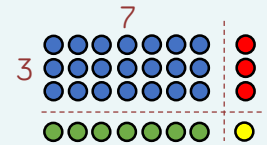

The red and green will always total 10 and the yellow will increase that by 1 to 11

# Area of a Triangle (1)

## Notes and Guidance

Children will use their previous knowledge of approximating and estimating to work out the area of different triangles by counting.

Children will need to physically annotate to avoid repetition when counting the squares.

Children will begin to see the link between the area of a triangle and the area of a rectangle or square.

## Mathematical Talk

How many whole squares can you see?

How many part squares can you see?

What could we do with the parts?

What does estimate mean?

Why is your answer to this question an **estimate** of the area?

Revisit the idea that a square is a rectangle when generalising how to calculate the area of a triangle.

## Varied Fluency

Count squares to calculate the area of each triangle.

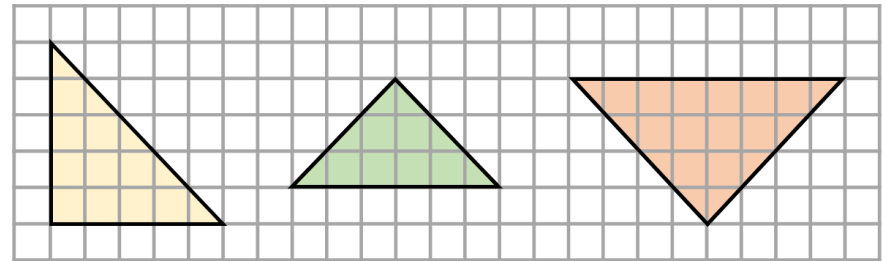

Estimate the area of each triangle by counting squares.

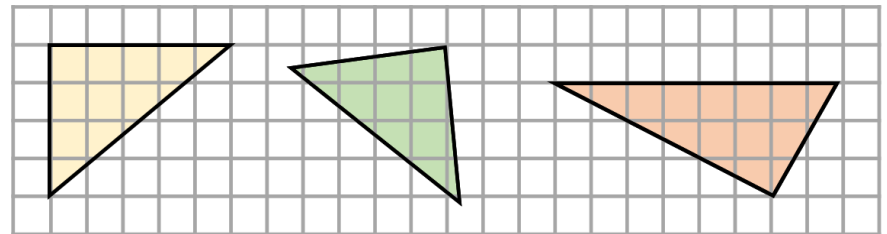

Calculate the area of each shape by counting squares.

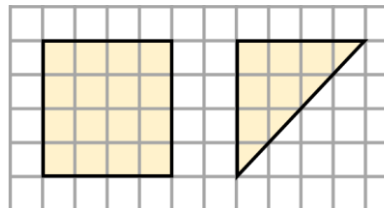

What do you notice about the area of the triangle compared to the area of the square?  
Does this always happen?

Explore this using different rectangles.



# Area of a Triangle (1)

## Reasoning and Problem Solving

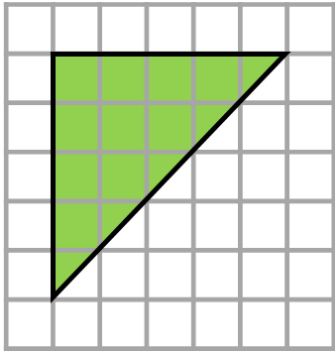

Mo is incorrect because he has counted the half squares as whole squares.

Mo says the area of this triangle is  $15\text{cm}^2$ . Is Mo correct? If not, explain his mistake.

Part of a triangle has been covered. Estimate the area of the whole triangle.

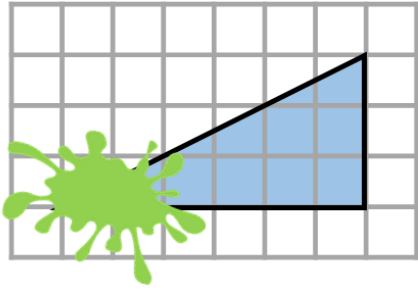

$9\text{ cm}^2$

What is the same about these two triangles?  
What is different?

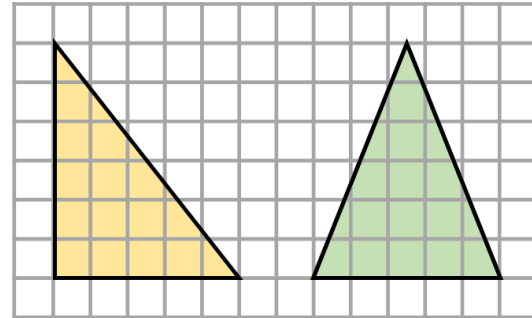

Can you create a different right angled triangle with the same area?

Both triangles have an area of  $15\text{ cm}^2$ .  
The triangle on the left is a right angled triangle and the triangle on the right is an isosceles triangle.

Children could draw a triangle with a height of 10 cm and a base of 3 cm, or a height of 15 cm and a base of 2 cm.

# Area of a Triangle (2)

## Notes and Guidance

Children use their knowledge of finding the area of a rectangle to find the area of a right-angled triangle. They see that a right-angled triangle with the same length and perpendicular height as a rectangle will have an area half the size.

Using the link between the area of a rectangle and a triangle, children will learn and use the formula to calculate the area of a triangle.

## Mathematical Talk

What is the same/different about the rectangle and triangle?

What is the relationship between the area of a rectangle and the area of a right-angled triangle?

What is the formula for working out the area of a rectangle or square?

How can you use this formula to work out the area of a right-angled triangle?

## Varied Fluency

- Estimate the area of the triangle by counting the squares.  
Make the triangle into a rectangle with the same height and width. Calculate the area.

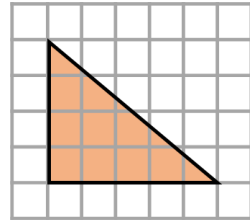

The area of the triangle is \_\_\_\_\_ the area of the rectangle.

- If  $l$  represents length and  $h$  represents height:

$$\text{Area of a rectangle} = l \times h$$

Use this to calculate the area of the rectangle.

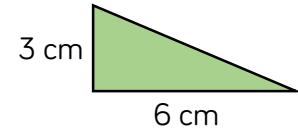
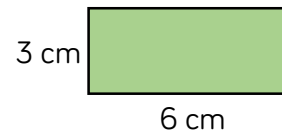

What do you need to do to your answer to work out the area of the triangle?

Therefore, what is the formula for the area of a triangle?

- Calculate the area of these triangles.

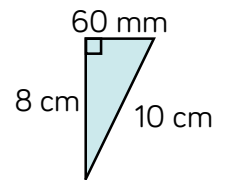
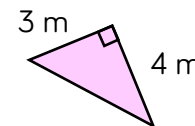
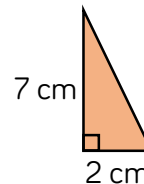

# Area of a Triangle (2)

## Reasoning and Problem Solving

Annie is calculating the area of a right-angled triangle.



I only need to know the length of any two sides to calculate the area of a triangle.

Do you agree with Annie? Explain your answer.

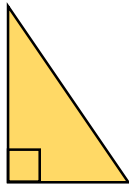

$$\text{Area} = 54 \text{ cm}^2$$

What could the length and the height of the triangle be?

How many different integer possibilities can you find?

Annie is incorrect as it is not sufficient to know **any** two sides, she needs the base and perpendicular height. Children could draw examples and non-examples.

Possible answers:

Height: 18 cm

Base: 6 cm

Height: 27 cm

Base: 4 cm

Height: 12 cm

Base: 9 cm

Calculate the area of the shaded triangle.

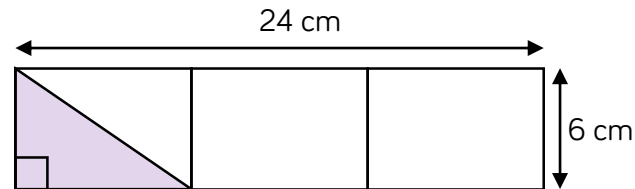

Mo says,



I got an answer of  $72 \text{ cm}^2$

Do you agree with Mo?

If not, can you spot his mistake?

The area of the shaded triangle is  $24 \text{ cm}^2$

Mo is incorrect as he has just multiplied the two numbers given and divided by 2, he hasn't identified the correct base of the triangle.

# Area of a Triangle (3)

## Notes and Guidance

Children will extend their knowledge of working out the area of a right-angled triangle to work out the area of any triangle.

They use the formula,  $\text{base} \times \text{perpendicular height} \div 2$  to calculate the area of a variety of triangles where different side lengths are given and where more than one triangle make up a shape.

## Mathematical Talk

What does the word perpendicular mean?

What do we mean by perpendicular height?

What formula can you use to calculate the area of a triangle?

If there is more than one triangle making up a shape, how can we use the formula to find the area of the whole shape?

How do we know which length tells us the perpendicular height of the triangle?

## Varied Fluency

- To calculate the height of a triangle, you can use the formula:  
 $\text{base} \times \text{height} \div 2$   
 Choose the correct calculation to find the area of the triangle.

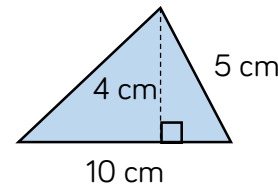

- $10 \times 5 \div 2$
- $10 \times 4 \div 2$
- $5 \times 4 \div 2$

- Estimate the area of the triangle by counting squares.

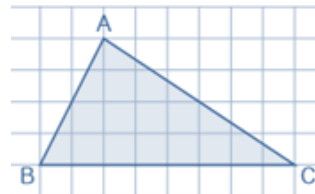

Now calculate the area of the triangle. Compare your answers.

- Calculate the area of each shape.

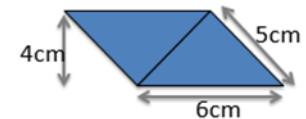
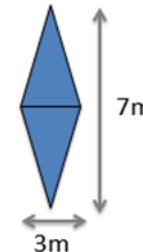
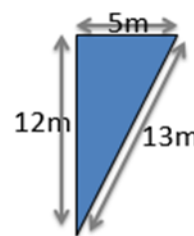

# Area of a Triangle (3)

## Reasoning and Problem Solving

Class 6 are calculating the area of this triangle.

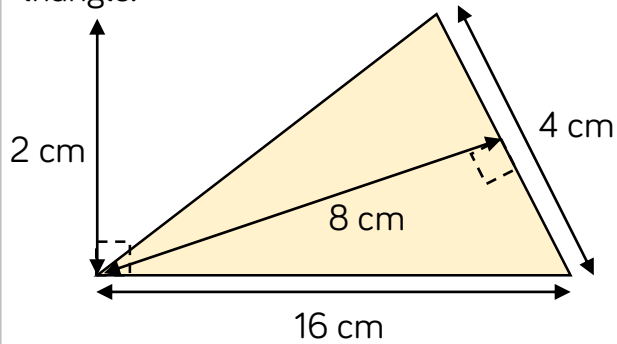

Here are some of their methods.

$$4 \times 8 \times 16 \times 2 \div 2$$

$$4 \times 8 \div 2$$

$$16 \times 2 \div 2$$

$$16 \times 4 \div 2$$

$$16 \times 8 \div 2$$

$$8 \times 1$$

Tick the correct methods.

Explain any mistakes.

The correct methods are:  
 $16 \times 2 \div 2$   
 $4 \times 8 \div 2$

All mistakes are due to not choosing a pair of lengths that are perpendicular.

Children could explore other methods to get to the correct answer e.g. halving the base first and calculating  $8 \times 2$  etc.

The shape is made of three identical triangles.

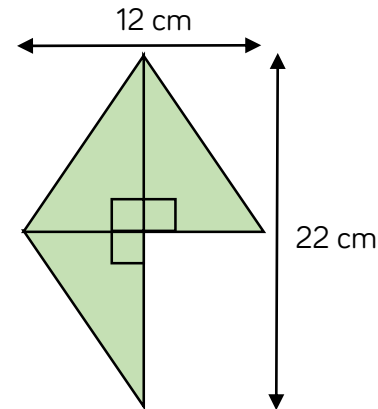

What is the area of the shape?

Each triangle is 6 cm by 11 cm so area of one triangle is  $33 \text{ cm}^2$

Total area =  $99 \text{ cm}^2$

# Area of a Parallelogram

## Notes and Guidance

Children use their knowledge of finding the area of a rectangle to find the area of a parallelogram.

Children investigate the link between the area of a rectangle and parallelogram by cutting a parallelogram so that it can be rearranged into a rectangle. This will help them understand why the formula to find the area of parallelograms works.

## Mathematical Talk

Describe a parallelogram.

What do you notice about the area of a rectangle and a parallelogram?

What formula can you use to work out the area of a parallelogram?

## Varied Fluency

- Approximate the area of the parallelogram by counting squares. Now cut along the dotted line. Can you move the triangle to make a rectangle? Calculate the area of the rectangle.

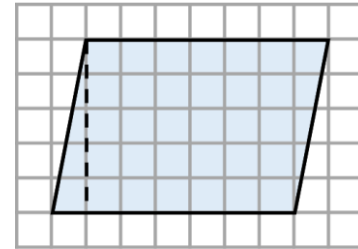

- Here are two quadrilaterals.

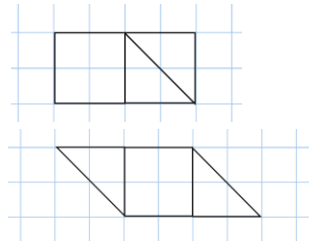

- What is the same about the quadrilaterals?
- What's different?
- What is the area of each quadrilateral?

- Use the formula  $\text{base} \times \text{perpendicular height}$  to calculate the area of the parallelograms.

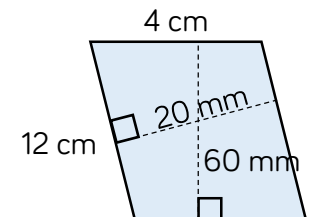
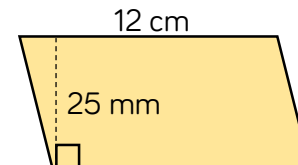
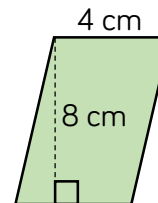

# Area of a Parallelogram

## Reasoning and Problem Solving

Teddy has drawn a parallelogram.

The area is greater than  $44 \text{ m}^2$  but less than  $48 \text{ m}^2$ .

What could the base length and the perpendicular height of Teddy's parallelogram be?

Possible answers:

$$9 \text{ m by } 5 \text{ m} = 45 \text{ m}^2$$

$$6.5 \text{ m by } 7 \text{ m} = 45.5 \text{ m}^2$$

$$11 \text{ m by } 4.2 \text{ m} = 46.2 \text{ m}^2$$

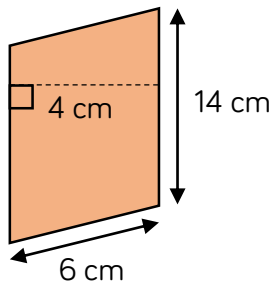

Dexter thinks the area of the parallelogram is  $84 \text{ cm}^2$ .

What mistake has Dexter made?

What is the correct area?

Dexter has multiplied 14 by 6 when he should have multiplied by 4 because 4 is the perpendicular height of the parallelogram. The correct area is  $56 \text{ cm}^2$ .

Dora and Eva are creating a mosaic.

They are filling a sheet of paper this size.

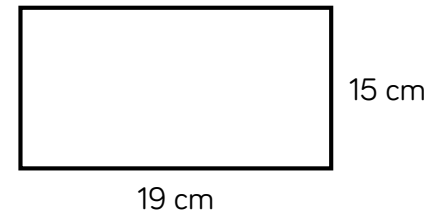

Dora is using tiles that are rectangular.

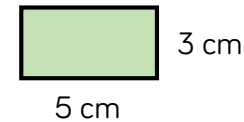

Eva's tiles are parallelograms.

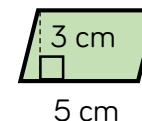

Dora thinks that she will use fewer tiles than Eva to fill the page because her tiles are bigger.

Do you agree? Explain your answer.

Dora is wrong because both hers and Eva's tiles have the same area and so the same number of tiles will be needed to complete the mosaic. The area of the paper is  $285 \text{ cm}^2$  and the area of each tile is  $15 \text{ cm}^2$  so 19 tiles are needed to complete the pattern.

# Volume – Counting Cubes

## Notes and Guidance

Children should understand that volume is the space occupied by a 3-D object.

Children will start by counting cubic units ( $1 \text{ cm}^3$ ) to find the volume of 3D shapes. They will then use cubes to build their own models and describe the volume of the models they make.

## Mathematical Talk

What's the same and what's different between area and volume?

Can you explain how you worked out the volume?  
What did you visualise?

What units of measure could we use for volume? (Explore  $\text{cm}^3$ ,  $\text{m}^3$ ,  $\text{mm}^3$  etc.)

## Varied Fluency

❖ If each cube has a volume of  $1 \text{ cm}^3$ , find the volume of each solid.

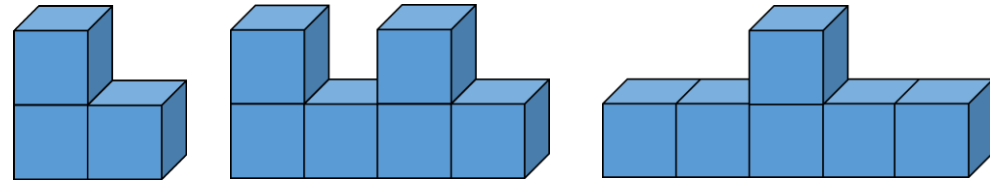

❖ Make each shape using multilink cubes.

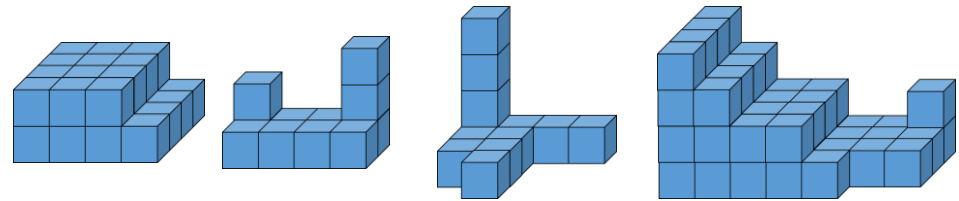

If each cube has a volume of  $1 \text{ cm}^3$ , what is the volume of each shape?

Place the shapes in ascending order based on their volume.  
What about if each cube represented  $1 \text{ mm}^3$ , how would this affect your answer? What about if they were  $1 \text{ m}^3$ ?

❖ If one multilink cube represents 1 cubic unit, how many different models can you make with a volume of 12 cubic units?



# Volume – Counting Cubes

## Reasoning and Problem Solving

Amir says he will need  $8 \text{ cm}^3$  to build this shape.

Dora says she will need  $10 \text{ cm}^3$ .

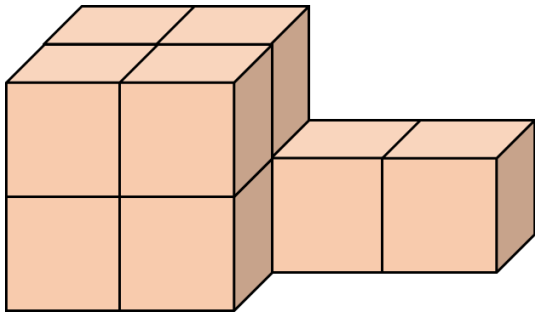

Who do you agree with?

Explain why.

Amir is incorrect because he has missed the 2 cubes that cannot be seen.

Dora is correct because there are  $8 \text{ cm}^3$  making the visible shape, then there are an additional  $2 \text{ cm}^3$  behind.

Tommy is making cubes using multilink. He has 64 multilink cubes altogether.

How many different sized cubes could he make?

He says,



If I use all of my multilink to make 8 larger cubes, then each of these will be 2 by 2 by 2.

How many other combinations can Tommy make where he uses all the cubes?

Tommy could make:

- $1 \times 1 \times 1$
- $2 \times 2 \times 2$
- $3 \times 3 \times 3$
- $4 \times 4 \times 4$

Possible answers:

64 cubes that are  $1 \times 1 \times 1$

2 cubes that are  $3 \times 3 \times 3$ ; 1 cube that is  $2 \times 2 \times 2$ ; 2 cubes that are  $1 \times 1 \times 1$

# Volume of a Cuboid

## Notes and Guidance

Children make the link between counting cubes and the formula ( $l \times w \times h$ ) for calculating the volume of cuboids.

They realise that the formula is the same as calculating the area of the base and multiplying this by the height.

## Mathematical Talk

Can you identify the length, width and height of the cuboid?

If the length of a cuboid is 5 cm and the volume is  $100 \text{ cm}^3$ , what could the width and height of the cuboid be?

What knowledge can I use to help me calculate the missing lengths?

## Varied Fluency

Complete the sentences for each cuboid.

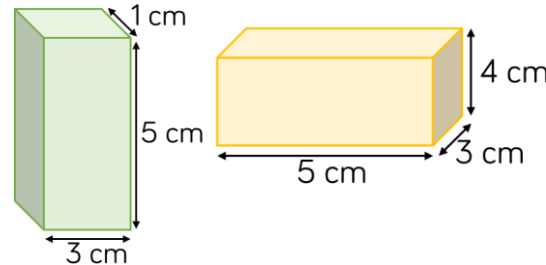

The length is: \_\_\_\_\_  
 The width is: \_\_\_\_\_  
 The height is: \_\_\_\_\_

The area of the base is:  $\text{_____} \times \text{_____} = \text{_____}$

Volume = The area of the base  $\times$   $\text{_____} = \text{_____}$

Calculate the volume of a cube with side length:

4 cm      2 m      160 mm

Use appropriate units for your answers.

The volume of the cuboid is  $32 \text{ cm}^3$ .

Calculate the height.

You might want to use multilink cubes to help you.

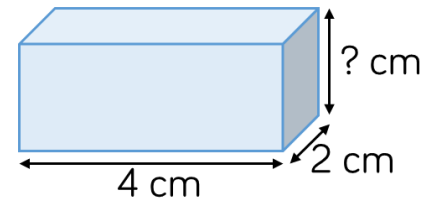

# Volume of a Cuboid

## Reasoning and Problem Solving

Rosie says,



You can't calculate the volume of the cube because you don't know the width or the height.

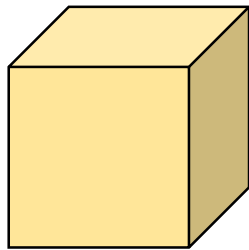

2 cm

Do you agree?

Explain why.

You don't need the rest of the measurements because it's a cube and all the edges of a cube are equal.

Therefore, the width would be 2 cm and the height would be 2 cm.

The volume of the cube is  $8 \text{ cm}^3$

Calculate the volume of the shape.

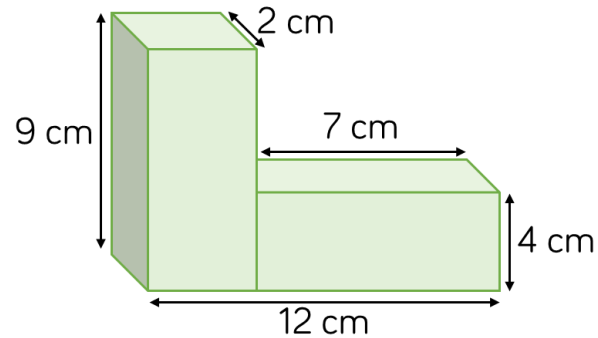

$146 \text{ cm}^3$

How many different ways can you make a cuboid with a volume of  $48 \text{ cm}^3$ ?

Possible answers:

$$24 \times 2 \times 1$$

$$2 \times 6 \times 4$$

$$6 \times 8 \times 1$$